



ABACO MACHINES

OPERATION MANUAL

**ABACO ONE STOP A-FRAME
(OSA6135)**



ABACO MACHINES (AUS)

Unit 4/34-36 Fairfield St., Fairfield East N.S.W 2165 Australia

Tel : 61-2-9632-4990

Email : Sales@abaco.com.au

Website : www.abaco.com.au

**APPLICABLE MODEL
of this ONE STOP A-FRAME:**

OSA6135

INDEX

Item	Page
I Equipment General Information.....	1
II Technical Specifications.....	1
1. Dimensions.....	2
2. Permissible Work Load Limit	2
3. Spare Part List	3
III Safety Instructions.....	6
1. General Warnings, Cautions and Notes.....	6
2. Device usage.....	7
IV Appendix	11
V Technical problems & Solutions.....	14
VI Inspection & Maintenance.....	14
VII Warranty Policy.....	15
Warranty Certificate.....	16

General Safety Operation Manual Instructions Summary:

It is essential to review carefully and understand this Operation Manual before operating the equipment. Failing to read and understand this entire manual may cause injury or death to personnel, or damage to the equipment and the products that are being handled by this equipment if not properly followed.

This safety summary includes general safety precautions and instructions that must be understood and applied before, during, and after operations, as well as maintenance to ensure personnel safety and protection of this equipment. Prior to performing any task, the contents included in this manual should be reviewed and fully understood.

This manual explains some essential operating or maintenance procedures, practices, conditions, statements, etc. that if those are not strictly followed, it could result in injury, or death by chance in the worst case. And there might be some chances of damaging or destructing materials or machine component itself. In order to avoid or eradicate such worst coincidences and happenings, it is essential to read through this manual and follow accordingly. It is also important to comprehend the functions of this equipment thoroughly for your safe and efficient operations.

For any question, please contact your local dealer or distributor.

I. EQUIPMENT GENERAL INFORMATION:

- The One Stop A-Frame is designed for transporting and storing stone slabs in warehouses, factories, or construction sites.
- The stone slabs will be protected safely via the rubber strips evenly arranged on the A-frame along with four ratchet securing bars.
- This A-frame can be separated into components and is convenient for packing and transporting.

II. TECHNICAL SPECIFICATIONS:

- The One Stop A-Frame is includes of two main parts: Base frame and A-frame. In addition, it has ratchet securing bars.
- The base frame is attached to four heavy duty casters. Two swivel casters can provide easy maneuvering in different directions.
- The ratchet securing bars are separated, the top is equipped with straps, the bottom has slots to clamp the ratchet securing bars. The ratchet securing bars can be moved depending on the size and number of slabs.

1. Dimensions:

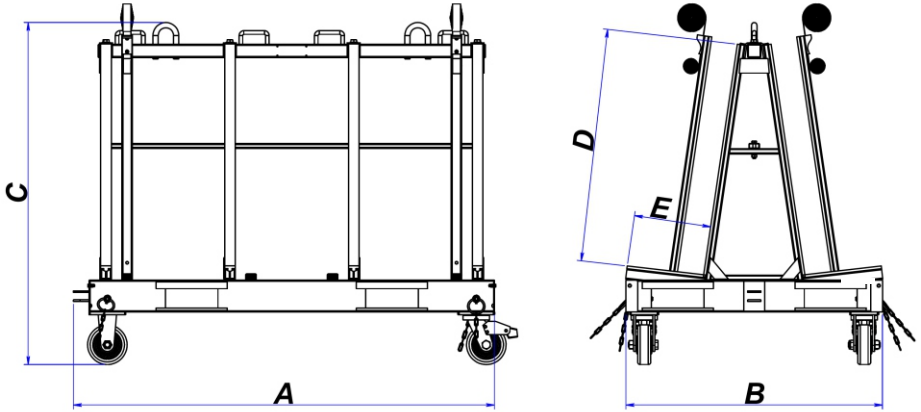

Length (A) inches (mm)	Width (B) inches (mm)	Height (C) inches (mm)	D inches (mm)	E inches (mm)
62 ¹⁵ / ₁₆ (1598)	38 ⁵ / ₁₆ (973)	51 ¹ / ₁₆ (1296)	35 ¹ / ₁₆ (890)	11 ⁷ / ₁₆ (290)

2. Permissible Work Load Limit (WLL):

- Lifting with Eyelets: 5500 lbs (2500 kg)
- Capacity with casters: 4400 lbs (2000 kg)
- Stationary w/o casters: 17600 lbs (8000 kg)

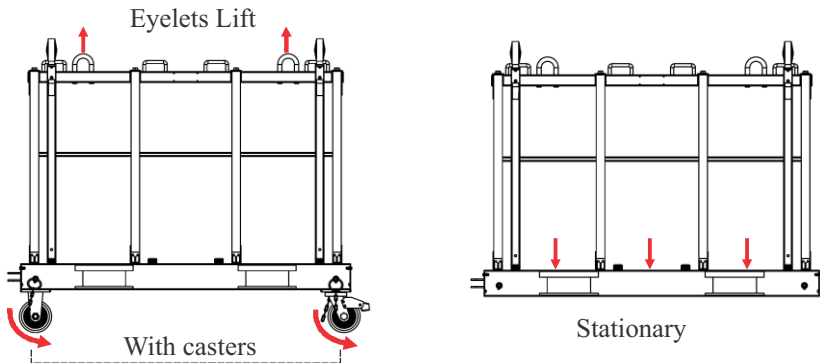

3. Spare part list:

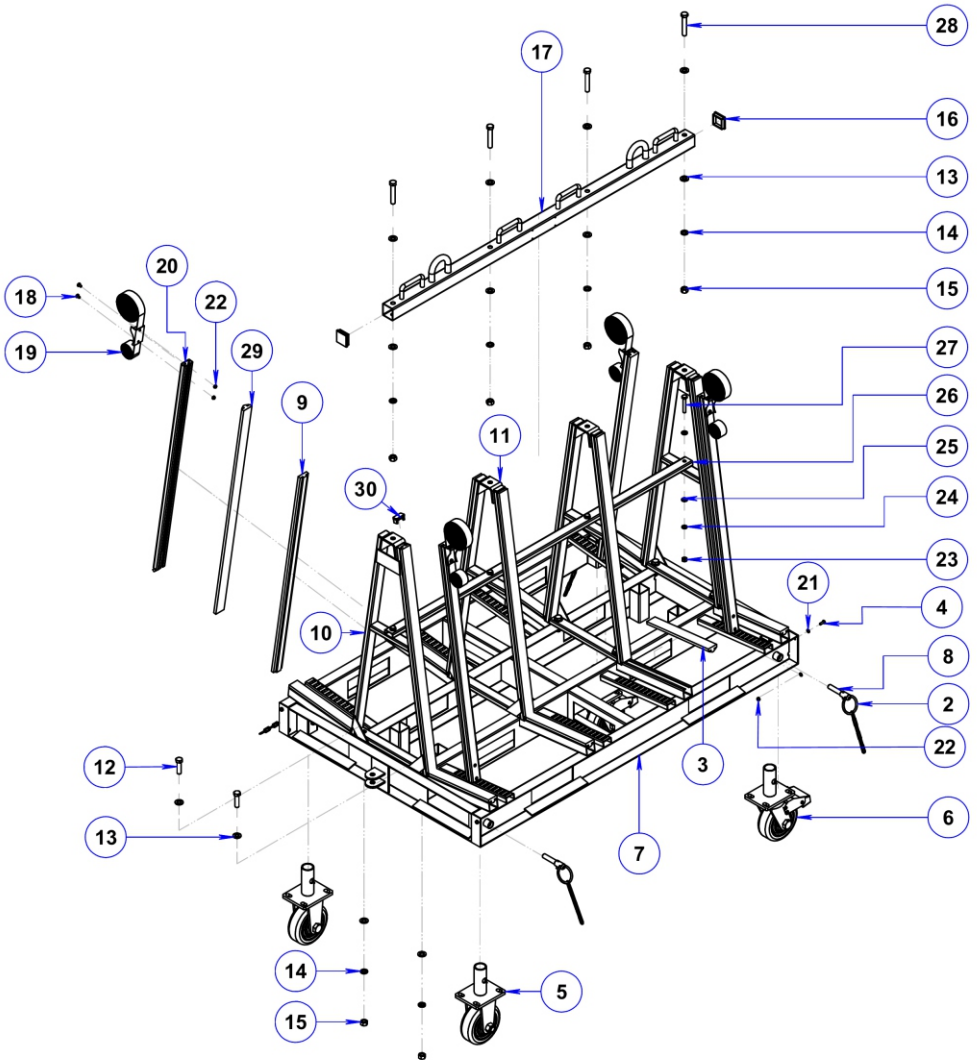

SPARE PART LIST

DESCRIPTION	PART NUMBER	QTY.
Chain	OSA6135-02	4
Rubber strip 3	OSA6135-03	8
Bolt M6 x 15	OSA6135-04	4
Rigid caster	OSA6135-05	2
Swivel caster w/brake	OSA6135-06	2
Base frame	OSA6135-07	1
Pin	OSA6135-08	4
Rubber strip 2	OSA6135-09	8
A frame 1	OSA6135-10	2
A frame 2	OSA6135-11	2
Bolt M14 x 50	OSA6135-12	8
Washer ø14	OSA6135-13	24
Spring washer ø14	OSA6135-14	12
Nut M14	OSA6135-15	12
Rubber cap 1	OSA6135-16	2
Top bar	OSA6135-17	1
Screw M6 x 10	OSA6135-18	8
Ratchet strap	OSA6135-19	4
Ratchet securing bars	OSA6135-20	4

DESCRIPTION	PART NUMBER	QTY.
Washer ø6	OSA6135-21	8
Lock nut M6	OSA6135-22	12
Nut M10	OSA6135-23	4
Spring washer ø10	OSA6135-24	4
Washer ø10	OSA6135-25	8
Intermediate bar	OSA6135-26	1
Bolt M10 x 60	OSA6135-27	4
Bolt M14 x 80	OSA6135-28	4
Rubber strip 1	OSA6135-29	4
Rubber cap 2	OSA6135-30	8

III. SAFETY INSTRUCTIONS:

1. General Warnings, Cautions and Notes:

a. Before operations:

- Make sure that the One Stop A-Frame is placed on a flat and smooth surface, not on a wavy or rough surface.
- Make sure that all the bolts and nuts are securely tightened.
- Use appropriate PPE (Personal Protective Equipment) to protect against injury.
- Check the rubber strips, ratchet straps and casters are in good conditions. If there is any damage or defect, replace it with a new one.
- Confirm all the welded joints are free from any defect or damage, such as separation, crack, and so forth.
- Lubricate the casters periodically.

b. During operations:

- Make sure the weight of the slabs being placed is within the specified WLL.
- The slabs should be evenly loaded on both sides of the One Stop A-Frame
- The slabs should be restrained in a proper manner during transporting.
- Follow the steps and instructions in the Operation manual.
- For your own safety, follow all the applicable laws and regulations in your area.

c. After operations:

- Clean the One Stop A-Frame thoroughly after each use.
- Lubricate four casters.
- Store in a well-ventilated place, avoid places with high heat or humidity.

2. Device usage:

a. Move A-frame by casters.

Step 1: Lock two swivel casters (Figure 1.1).

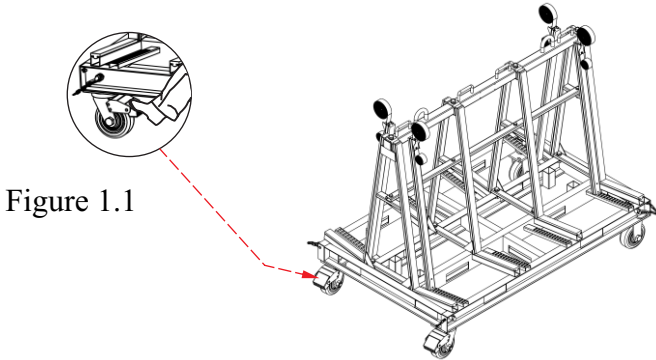

Figure 1.1

Step 2: Place the stone slabs on the A-frame (Figure 1.2).

Note:

- *The slabs should be evenly loaded on both sides of the A-frame.*
- *The stone slabs must lean against the frame (Figure 1.3).*
- *The height of the slab shall not be more than 300mm from the top of the A-frame (Figure 1.3).*
- *Maximum load capacity of all casters is 2000kg.*

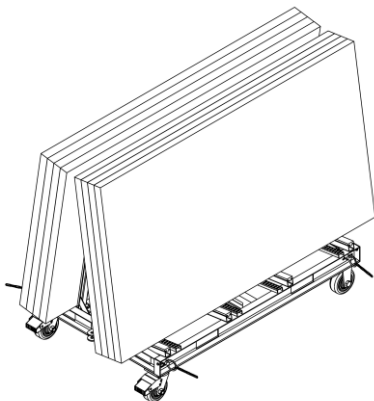

Figure 1.2

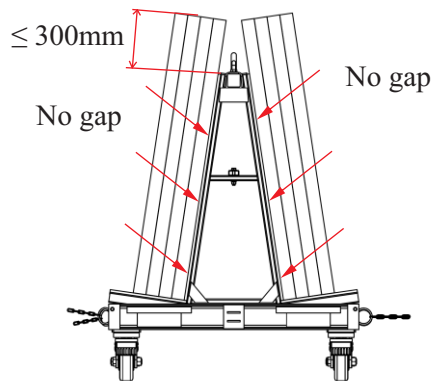

Figure 1.3

Note: No gap

Step 3: Install ratchet securing bars to restrain the slabs (Figure 1.4).

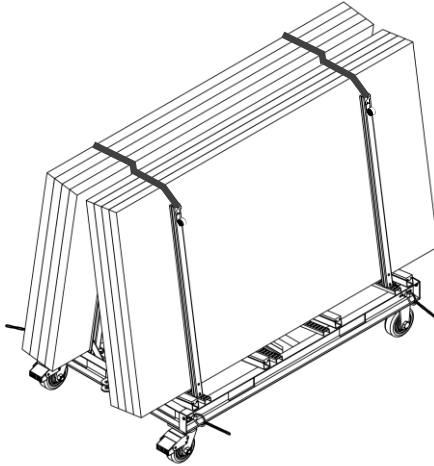

Figure 1.4

b. Move the A-frame by forklift truck (or crane).

Step 1: Remove four casters (Figure 2.1).

Lift the A-frame by forklift truck, then remove the 4 casters and put them inside the A-frame.

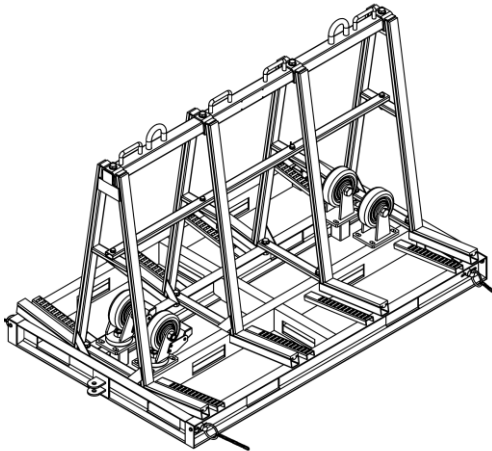

Figure 2.1

Step 2: Place the stone slabs (Figure 2.2).

Note:

- The slabs should be evenly loaded on both sides of the A-frame.
- The height of the slabs is not higher than the height of the A-frame to apply the hook into the eyelets to move the A-frame (Figure 2.7).

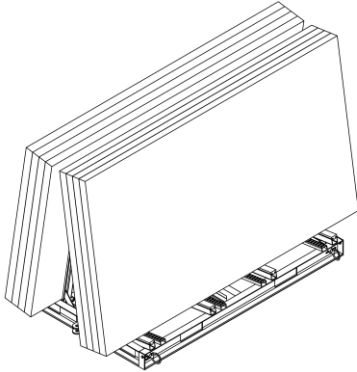

Figure 2.2

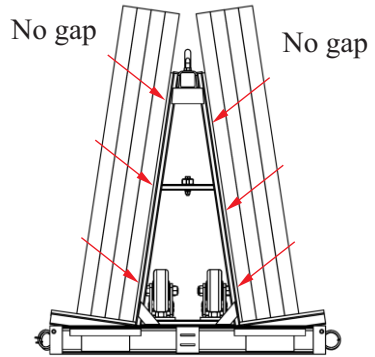

Figure 2.3

Step 3: Install ratchet securing bars (Figure 2.4)

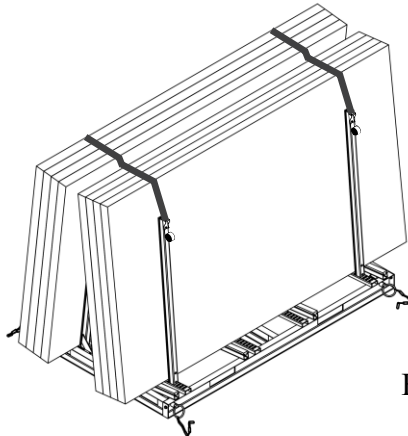

Figure 2.4

Step 4: Move the A-frame by a forklift truck.

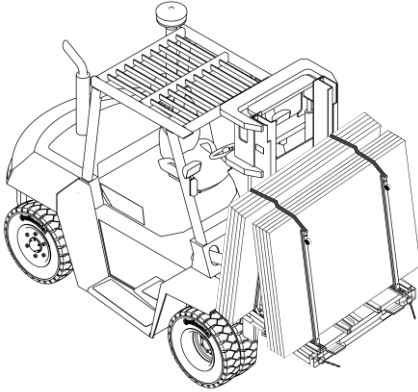

Figure 2.5

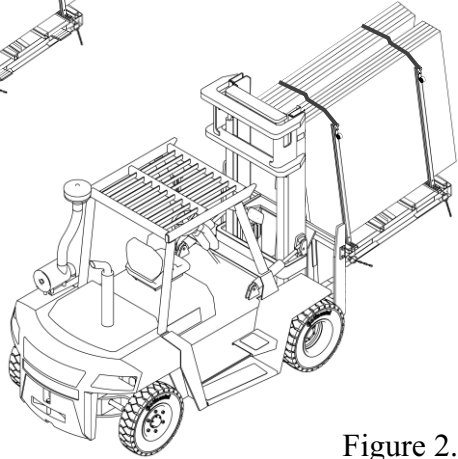
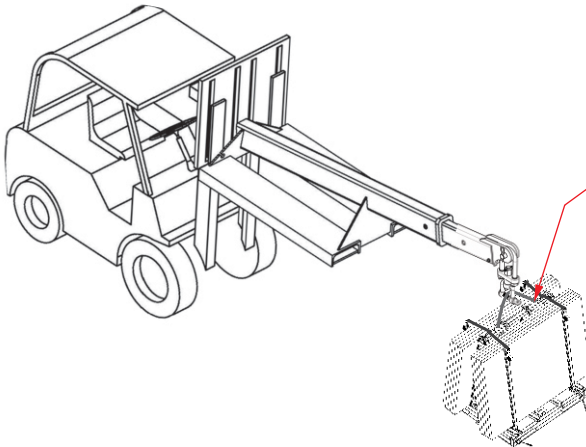

Figure 2.6



***Note:** Before lifting by eyelets, the operator must confirm the height of the slabs do not exceed the height of the A-frame.*

Figure 2.7

IV. APPENDIX:

1. Assembly instruction for A-Frame:

Step 1: Install the A-frame (10) and (11) into the base frame (7), fix it by using M14x50 bolt (12), Ø14 washer (13), Ø14 spring washer (14) and M14 nut (15).

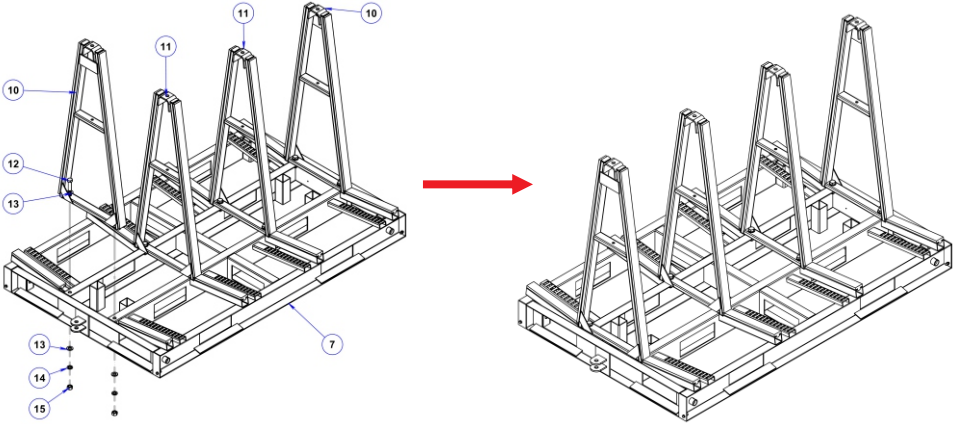

Step 2: Install the intermediate bar (26) into the A-frame (1), fix it by using M10x60 bolt (27), Ø10 washer (25), Ø10 spring washer (24) and M10 nut (23).

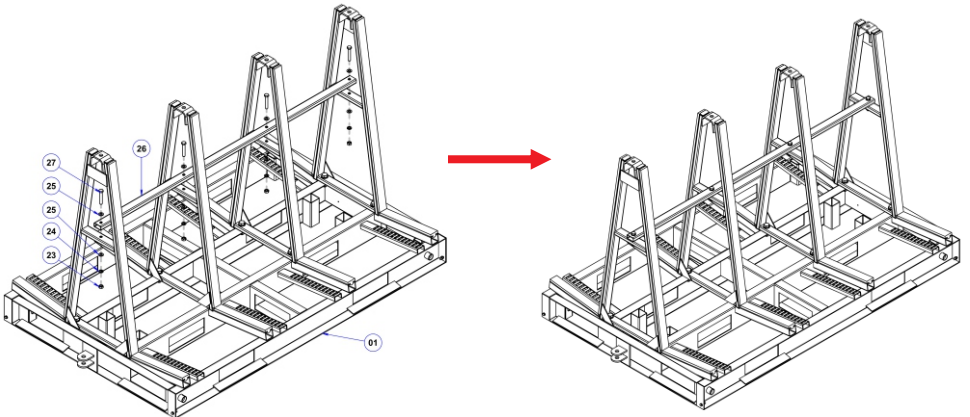

Step 3: Install the top bar (17) into the A-frame (1), fix it by using M14x80 bolt (28), Ø14 washer (13), Ø14 spring washer (14) and M14 nut (15).

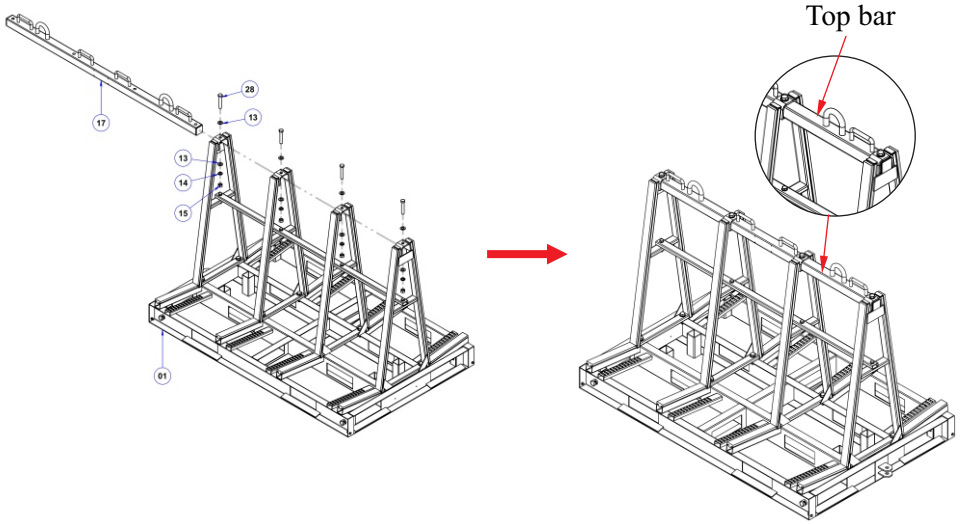

2. How to use the ratchet straps:



Figure 3.1

- To thread the strap, start from underneath the ratchet and push it up through the mandrel (spindle) (Figure 3.2).
- Flip the ratchet back into the closed position.



Figure 3.2

- Pull all the excess wire aside and continue feeding the strap through the mandrel until it feels taut. (Figure 3.3).



Figure 3.3

- Flip the ratchet up and down to tighten the strap (Figure 3.4). Once tightened, fold the ratchet down to lock and keep it during the operation. (Figure 3.5).

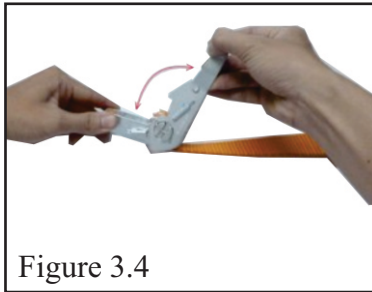

Figure 3.4

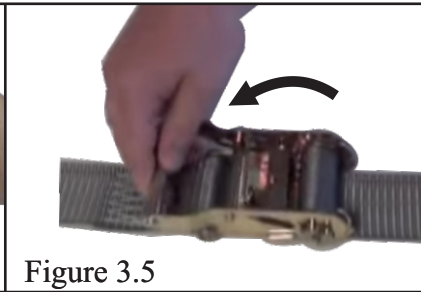

Figure 3.5

- To release or remove the strap, pull the lever firmly and open the ratchet widely (Figure 3.6).

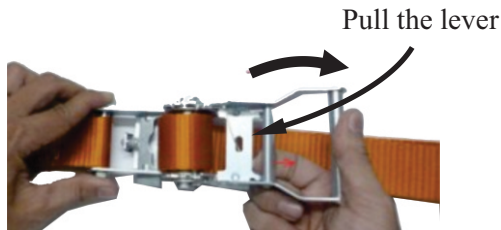

Figure 3.6

- Pull the strap out of ratchet (Figure 3.7).



Figure 3.7

V. TECHNICAL PROBLEMS & SOLUTIONS:

Technical problems	Causes	Solutions
The swivel casters are hard to move	Rust and/or dust, bearing is damaged	Clean, lubricate or replace with a new one
Rubber strips are damaged	Worn out or cracked	Replace with a new one
The straps are damaged	Worn out or cracked	Replace with a new one

VI. INSPECTION & MAINTENANCE:

- Equipment must be regularly checked and maintained.
- Schedule periodic maintenance.
- Always keep necessary spare parts on hand for maintenance or repair.
- Confirm all the welded joints are free from any defects or damage, such as separation, crack, and so forth.
- Store in a well-ventilated place, and avoid places with high heat or humidity.

VII. WARRANTY POLICY:

At the time of delivery, it is necessary to inspect the **One Stop A-Frame (OSA6135)** to make sure that it has not been damaged during shipment. The product at the time of dispatch is warranted to be free from defects in material or workmanship.

Claims for errors, shortages, defects, or nonconformities ascertainable upon inspection must be made in writing within eight business days from the date of product delivery. Claims not made as provided above and within the applicable time period will be barred. And no other claims will be considered.

We provide a one (1) year warranty on the **One Stop A-Frame (OSA6135)** from the date of purchase.

During warranty period, we will provide the replacement parts at no charge (*Please note:* shipping and handling fees may apply).

Warranty coverage is void if:

- The operator failed to comply with the instructions in the manual.
- The specifications were not followed.
- Damage was due to inadequate maintenance and inspections.
- Damage was due to improper storage and/or usage.
- Modification and repairs made to the equipment were performed by the user/operator without the manufacture's knowledge and agreement.
- Aftermarket or none genuine spare parts were used for repair installation.
- Modification and repair installations were conducted by uncertified individual.

WARRANTY CERTIFICATE

You are kindly requested to read the following carefully.

PERIOD

The warranty starts from the date of purchase (date on distributors invoice).

Warranty is valid for a period of twelve (12) months.

WARRANTY

This warranty is limited only to provide replacements of the parts recognized by the Company as defective (excluding worn-outs and consumables.)

The Company is not responsible for any misuse or abuse of the product after purchase and/or caused by negligence from the content of this manual.

In an event of equipment failure to operate the machine and/or requiring technical support, operator/user is requested to contact with our Customer Support Department. Our member will inform you (operator/user) of the appropriate procedures accordingly and how to file warranty claim and advise you to your nearest approved service center.

EXCLUSIONS

Warranty does not apply for damages or failures caused by:

Misuses, errors in transportation, incorrect handling or failing to maintain the equipment appropriately.

Use of non-genuine parts/accessories, or of incorrect specifications.

THIS MANUAL SHALL BE REVISED WITHOUT PRIOR NOTICE
FOR IMPROVEMENT PURPOSES
DO NOT COPY AND/OR QUOTE THE CONTENTS WITHOUT
PRIOR WRITTEN CONSENTS.

All Rights Reserved:
G23

